



8041 Arrowridge Blvd., Suite G, Charlotte, NC 28273 USA
 Tel: +1 (704) 714-3494 Fax: +1 (704) 714-3496
 sales@abaltd.com www.abaltd.com

Automatic Top Fill Volumetric Filling Machines

- Pneumatically or PLC controlled filling machine.**
- Fills Pint through Gallon Containers.**
- Automatic Operation.**
- One through four fill Stations.**
- 1 Gallon Double Acting Pump(s)**
- Single Integrated Platform.**
- Continuously Running Conveyor.**
- Optional Lid Dropper and Lid Press**
- Explosion Proof**



- Pneumatically or PLC Controlled filling machine.**
- Fills Pints Through 5 Gallon Containers.**
- Automatic Operation.**
- One through four fill Stations.**
- 1 Gallon Double Acting Pump(s)**
- Optional Integrated Pump Stroke Counter for Multi-Stroking the Pumps allows for ANY Size Product Levels.**
- Continuously Running Conveyor**

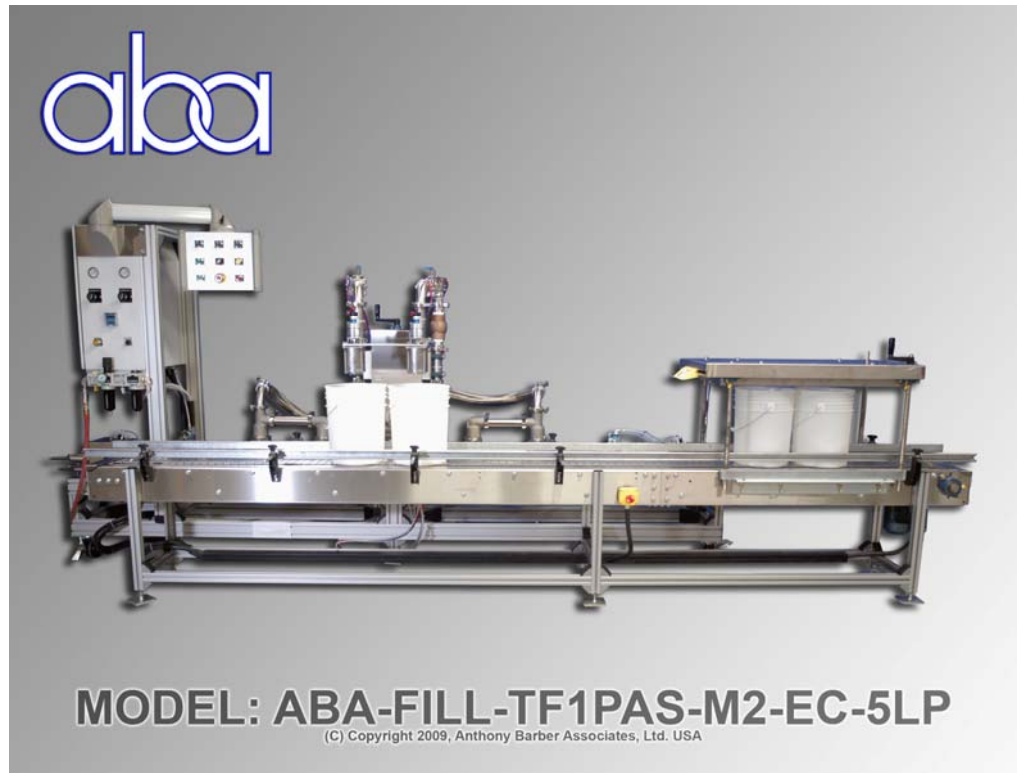



8041 Arrowridge Blvd., Suite G, Charlotte, NC 28273 USA
 Tel: +1 (704) 714-3494 Fax: +1 (704) 714-3496
 sales@abaltd.com www.abaltd.com

CAPACITIES AND PERFORMANCE:

Number Of Fill Heads	Container Size	Containers per Minute (*)	Pneumatic Consumption (SCFM @ 80 psi)	Electric Consumption (Kw.)	Un-crated weight (lbs.)	Number Of Conveyors
1	½ & 1 Pint	30	1.0	½	1050	1
	Quart (1 lt.)	25	1.3			
	Gallon (4 lt.)	15 - 20	3.0			
2	½ & 1 Pint	60	1.0	½	1200	1
	Quart (1 lt.)	50	2.5			
	Gallon	30 - 40	6.0			
3	½ & 1 Pint	60	1.5	½	1400	1
	Quart (1 lt.)	60	3.0			
	Gallon (4 lt.)	42 - 55	8.5			
4	½ & 1 Pint	120	3.0	1	1600	1
	Quart (1 lt.)	100	5.0			
	Gallon (4 lt.)	48 - 60	12.0			

ABA-COV-85 Cone fill head

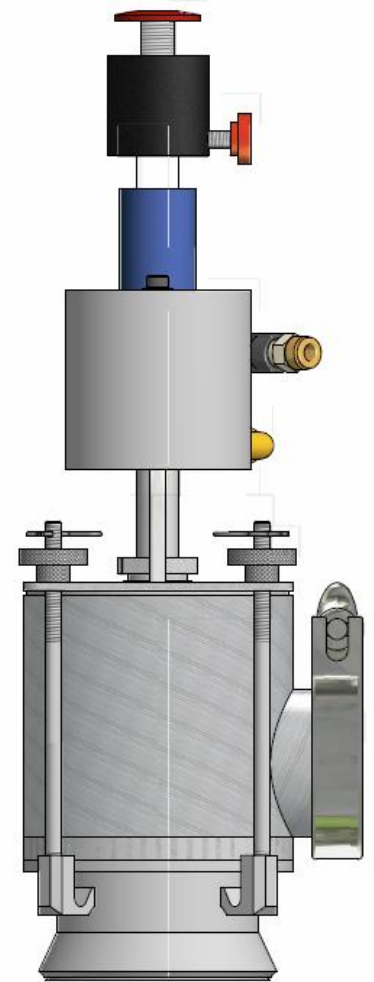

(*) - Containers per minute are dependent on container size, shape and fill opening as well as individual product characteristics.
 Swing head feature only available on single and dual head machines.

ABA-FILL-TF1PAF-S2-EC-1LP-LD-X

